

DAWN ENTERPRISES INC.

9155 Sweet Valley Dr., Valley View, OH 44125
Phone: (216) 447-1777 or (800) 548-4867
Fax: (216) 447-3416
www.dawn-ent.com

INSTALLATION INSTRUCTIONS

PART NUMBER: CUS-MAL13
FOR: 2013 + UP Chevrolet Malibu
EFFECTIVE: August 10, 2012

INSTALLATION PACKAGE INCLUDES:

- A) 4 – ¼-20 Flange Nuts
- B) 2 – Templates: One for the driver's side and one for the passenger side
- C) Adhesive Pads (for an unpainted Sportwing®)
- D) Instruction Sheet
- E) 4 – Hole Caps 1" to cover holes made in secondary panel.
- F) 4 – Threaded Studs

Extra tools needed: 1/8" or similar drill bit, 1" Hole Saw Uni-Bit to open 1/8" pilot holes to 3/8"

PLEASE READ ALL INSTRUCTIONS BEFORE BEGINNING INSTALLATION

1. CLEAN AND PREP

For proper installation of Sportwing®, clean the surface where the Sportwing® is to be installed using car wash soap and water. Before you install the part, please examine the spoiler against the car in natural sunlight. Check to make sure the paint colors match and that there are no paint flaws. If the Sportwing® is defective in any way, contact us and do not proceed with the installation.

2. REMOVE TRUNK LINER! Close the trunk.

3. Measure down 11" from the front corner of the trunk lid where it meets the rear window glass and make a mark with a grease pencil. See diagram below.

4. On the driver's side, align the provided driver's side template with the edge of the trunk at the 11" mark. See diagram below. Use masking tape to adhere the template to the deck lid, and repeat using passenger side template.



5. Drill 1/8" or similar pilot hole through the exact center of the two (2) fastening holes location on the template, through the top panel ONLY of the deck lid. Repeat procedure on passenger side using passenger side template.

6. Open the deck lid. See diagram below for fastening hole drilling instructions as to where to drill holes in the secondary panel inside of deck lid. This will allow you later on in the installation to give you access to the top panel when fastening flange nuts provided onto threaded bolts of Sportwing®. 1" Black hole caps have been provided for these holes upon finishing. Also, your trunk liner that you removed in step #2 will cover all fastening holes.

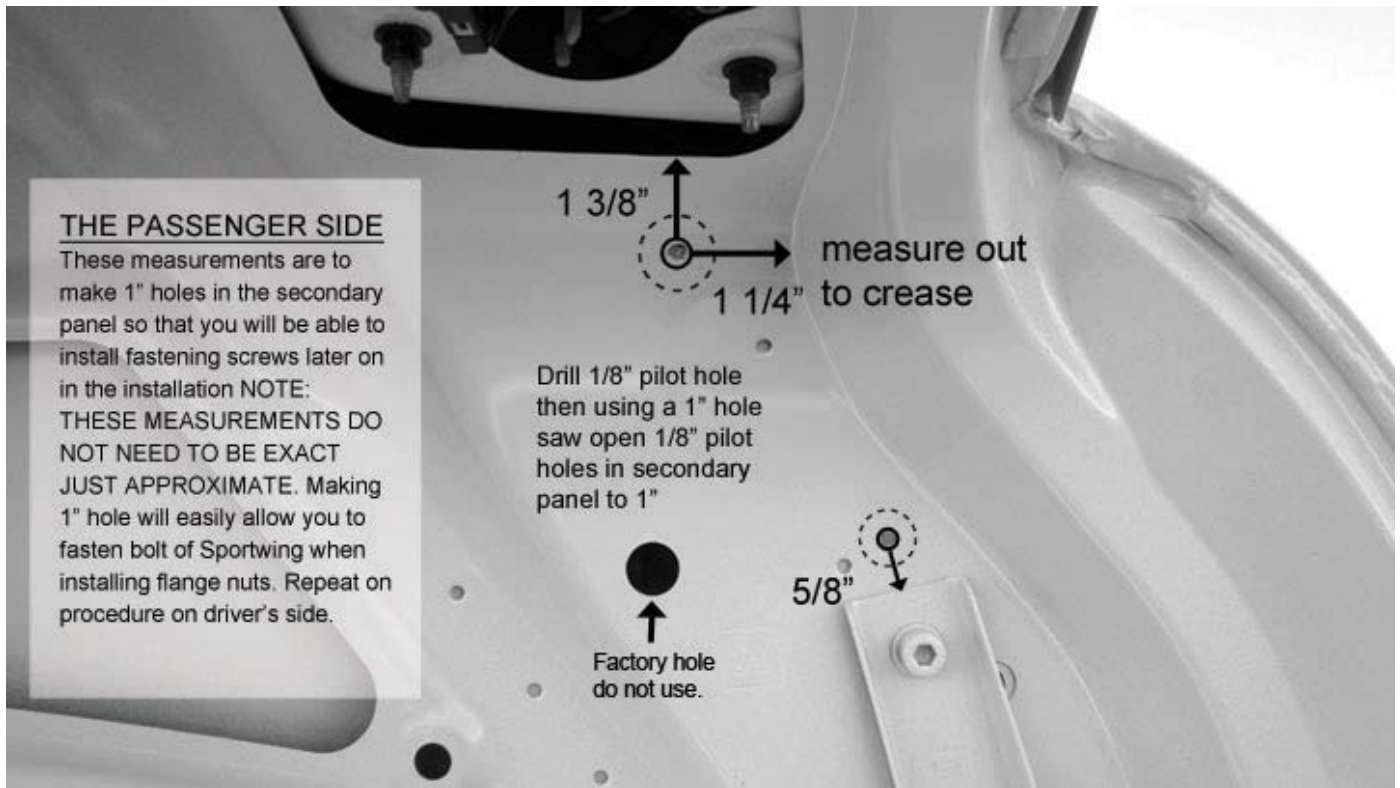

7. Close deck lid and remove the templates from the top of the deck lid. Next, using a uni-bit (we suggest using a uni-bit for a cleaner cut), open up the four (4) 1/8" pilot holes to 3/8".
8. Carefully place the Sportwing® onto the deck lid by placing the four (4) threaded bolts through the four (4) 3/8" holes that you made in the deck lid. The threaded bolts should align through the 3/8" holes without binding. You may need to file some of the 3/8" holes if the threaded bolts are hitting the edges of the 3/8" holes. Set Sportwing® aside when you are satisfied with the fit. Always be sure to set the Sportwing® on a soft cloth to avoid scratching its paint.
9. Apply zinc chromate primer or touch up paint on the edges of the four (4) 3/8" holes on the deck lid.
10. Place the Sportwing® back into the 3/8" holes. Holding onto Sportwing®, open deck lid and install the four (4) flange nuts and only finger tighten them. Once all flange nuts are started, tighten evenly (but do not over tighten).
11. Clean up any metal shavings, and you are done. If you have any questions, or if you would like information about other quality Sportwing® products, please call the TOLL FREE number at the top of this sheet. Thank you for choosing Dawn Enterprises Inc.