

DAWN ENTERPRISES INC.

9155 Sweet Valley Dr., Valley View, OH 44125
Phone: (216) 447-1777 or (800) 548-4867
Fax: (216) 447-3416
www.dawn-ent.com

INSTALLATION INSTRUCTIONS

PART NUMBER: LCM-Q7-417
FOR: 2010-2012 Audi Q7
EFFECTIVE: 19 March 2012

PLEASE READ ALL INSTRUCTIONS BEFORE BEGINNING INSTALLATION

1. **LOCATION** (See diagram below)
Run masking tape **as shown using measurements in Diagram A below** from POINT A to POINT B.
Press tape against the vehicle, making sure that the tape is straight from POINT A to POINT B.

DIAGRAM A



Measure up from factory cladding. Masking tape will sit just above factory crease.

2. **ALIGNMENT** (See diagram below)
The molding will sit just below the factory crease, and since it has tapered ends, the points of the molding will be slightly below the masking tape line. Near the door crease at the front of the car, and near the wheel well at the rear, measure down $\frac{5}{8}$ " from the masking tape line and make a mark with a grease pencil.

DIAGRAM B

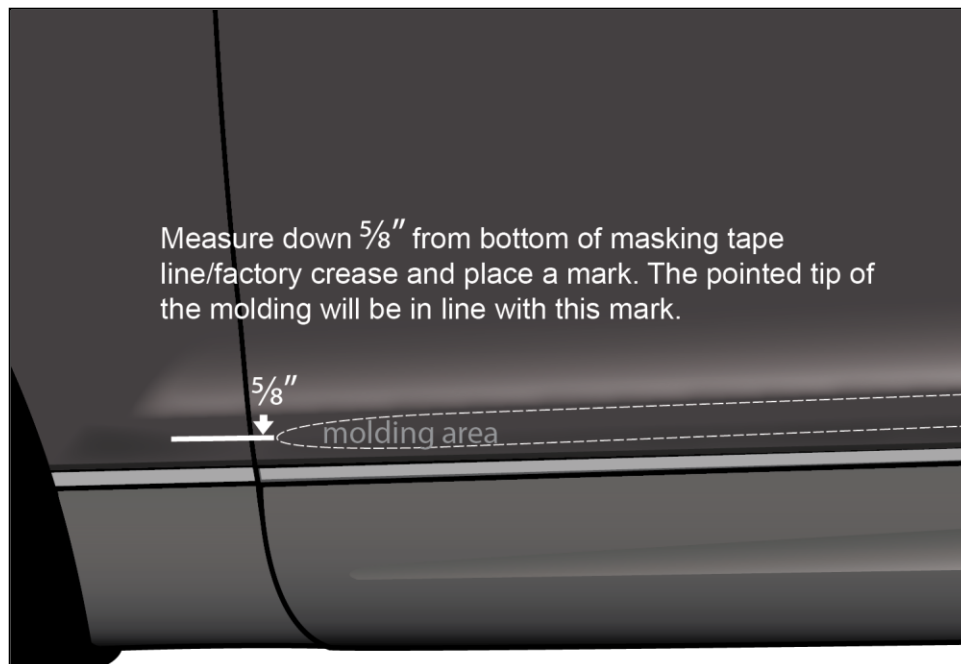

3. **CLEAN AND PREP:**

Clean the surface where the molding is to be installed using the enclosed alcohol pads for proper installation of Chrome Molding. Wipe off excess residue with a clean cloth. Next, apply **PRO-BOND ADHESIVE PROMOTER** in the crush swab self-applicator. Squeeze the applicator until you feel the applicator “crush.” The applicator will become wet on the end and is ready for use. Apply a thin coat of **PRO-BOND** below the masking tape line, only on the shaded area, **as shown in Diagram C**. Do not apply **PRO-BOND** in any area that the molding will not cover, as **PRO-BOND** could dull the paint surface. The light coat of **PRO-BOND** will dry quickly. Where cooler temperatures prevail, make sure the molding is at room temperature. The recommended metal surface temperature of the vehicle should be at least 75°F/24°C for proper installation. If the surface is cold, use a heat gun or hair dryer to warm before proceeding with installation.

DIAGRAM C

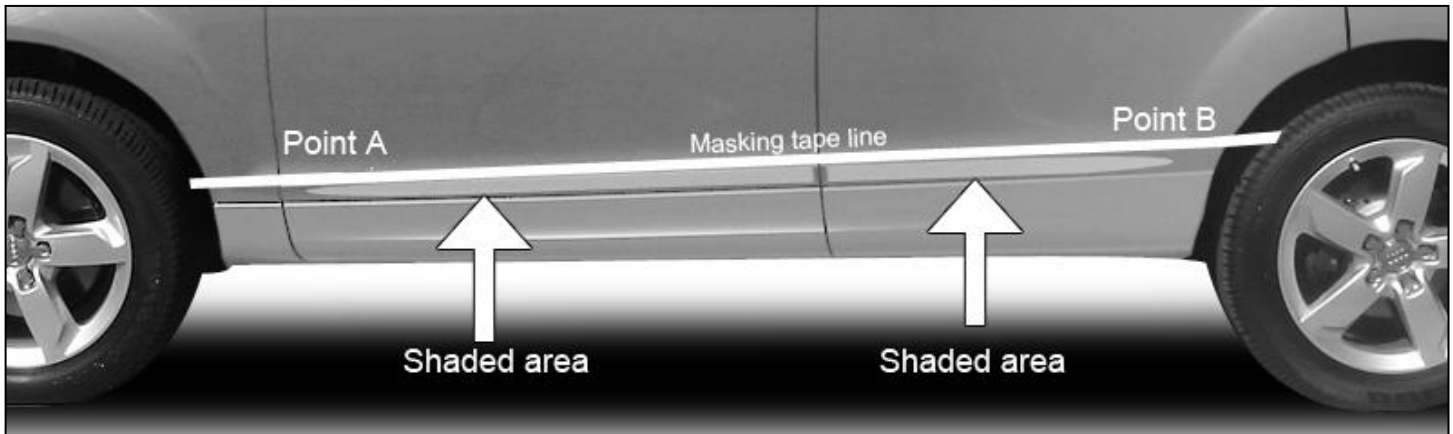

3. **INSTALLATION (IMPORTANT):**

Before starting, see Diagram D as to where to start applying molding. Next, completely peel off all of the liner from back of molding, making sure die cut ends of red liner are also removed from molding. **DO NOT TOUCH** the exposed adhesive with your fingers as you install the molding.

Since these moldings have been pre-cut, start adhering the moldings' rear piece first with the angle or bevel cut first and the finished end directed toward the rear wheel well. Next, install front door molding **following Diagram D** measurements.

DIAGRAM D

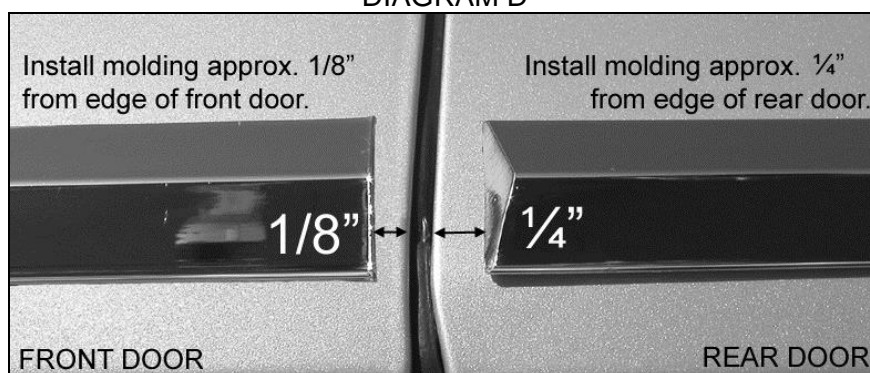

4. **AFTER THE MOLDING** has been installed, use a soft cloth to apply pressure along the entire length of the molding to insure proper adhesion.